

FANDHER^{MR}

**BURILES
CALZADOS**
BRAZED TOOLS

MX
HECHO EN
MÉXICO

FNH20A

BURILES

SINGLE POINTS TOOLS ESTILOS AR Y AL

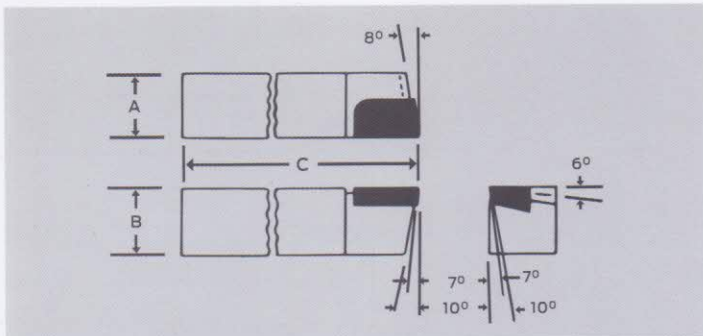

Las herramientas estilo A, han sido diseñadas para torneado interiores, exteriores y para refrentar a 90°.

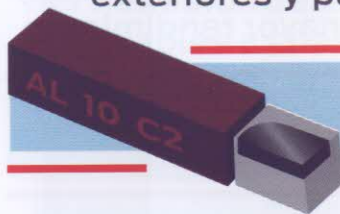

AL 10 C2

Style A tools, have been designed for latheing interior, exterior and facing at 90° angle.

AR 10 C6



ESTILO		PASTILLA		A		B		C	
AR-4	AL-4	2040	2040	6.3	1/4"	6.3	1/4"	50.8	2"
AR-5	AL-5	2070	2070	7.9	5/16"	7.9	5/16"	57.1	2 1/4"
AR-6	AL-6	2070	2070	9.5	3/8"	9.5	3/8"	63.5	2 1/2"
AR-7	AL-7	2070	2070	11.1	7/16"	11.1	7/16"	76.2	3"
AR-8	AL-8	2170	2170	12.7	1/2"	12.7	1/2"	88.9	3 1/2"
AR-10	AL-10	2230	2230	15.8	5/8"	15.8	5/8"	101.6	4"
AR-12	AL-12	2310	2310	19.0	3/4"	19.0	3/4"	114.3	4 1/2"
AR-16	AL-16	3390	4390	25.4	1"	25.4	1"	178.0	7"
AR-20	AL-20	3460	4460	31.7	1 1/4"	31.8	1 1/4"	203.0	8"
AR-24	AL-24	3510	4510	38.1	1 1/2"	38.1	1 1/2"	203.0	8"
AR-44	AL-44	2260	2260	12.7	1/2"	25.4	1"	178.0	7"
AR-54	AL-54	3360	4360	15.8	5/8"	25.4	1"	152.0	6"
AR-55	AL-55	3360	4360	15.8	5/8"	31.7	1 1/4"	203.0	8"
AR-64	AL-64	3380	4380	19.0	3/4"	25.4	1"	152.0	6"
AR-66	AL-66	3430	4430	19.0	3/4"	38.1	1 1/2"	203.0	8"
AR-85	AL-85	3460	4460	25.4	1"	31.7	1 1/4"	203.0	8"
AR-86	AL-86	3510	4510	25.4	1"	38.1	1 1/2"	203.0	8"
AR-88	AL-88	3510	4510	25.4	1"	50.8	2"	254.0	10"
AR-90	AL-90	3540	4540	38.1	1 1/2"	50.8	2"	203.8	8"

GRADO C6 C2